

# absolute prefilter kits

## Prefilter Kits for Absolute Built-up Bank Installations

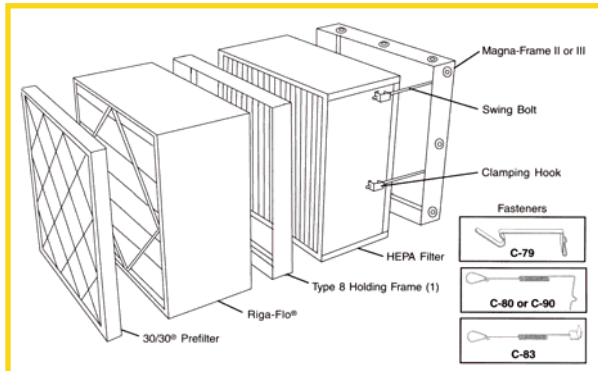

Combines absolute, high efficiency ASHRAE filter and prefilter in one easy to service assembly



Top left: Camfil Farr 30/30°

Top right: Camfil Farr Durafil®

Bottom left: Camfil Farr Riga-Flo®

Bottom right: Camfil Farr Aeropac®

Camfil Farr Absolute Prefilter Kits allow installation of Camfil Farr's wide variety of prefilters in front of absolute filters as installed in Camfil Farr's Magna-Frame I/II/III holding frames or Magna-Grid built-up bank systems. The kits include the Camfil Farr Type 8 frame (for full-size), or an adapter frame (for undersized), and swing bolt assemblies to install one or two stages of prefiltration upstream of the absolute filters. All standard features are incorporated, including a 3/4" sealing flange, factory applied polyurethane foam gasket, dimples which automatically center the filters and lances for accepting the various fasteners for a wide selection of prefilters. The prefilters may include Camfil Farr's 2" or 4" deep 30/30° and any of our 6" or 12" deep rigid filters.

Research indicates that proper prefiltration extends the life of absolute filters 45 to 800 percent, dependent upon the level of prefiltration applied. Additionally, there is an increased emphasis on reducing downstream particle counts in spaces ranging from health care applications, to food processing and traditional clean manufacturing spaces, such as pharmaceutical and electronics industries. Good prefiltration reduces downstream particle counts in those applications, by reducing the load of particulate to which each increasing level of higher efficiency filtration is exposed. The prefilter protects the ASHRAE high efficiency filter and the high efficiency ASHRAE filter protects the absolute filter, resultant in an extended final filter life and cleaner spaces.

When combined with the swing bolt assemblies, the entire bank will meet the positive sealing integrity required of the absolute filter and provide a single side, front access servicing system.

<sup>1</sup> Durafil is only available in 12" deep configuration.



Camfil Farr	Product sheet
Magna-Frame Prefilter Kits	2902K - 0606
Camfil Farr—clean air solutions	

# PERFORMANCE DATA

## Prefilter kits applied to 'full size' absolute filters

Material	Actual Dimensions (inches)		Actual HEPA Filter Dimensions		Depth (inches)
	Height	Width	Height	Width	
Galvanized Steel <sup>A</sup>	24.62	24.62	24	24	6 (5.88)
	24.62	12.62	24	12	
	12.62	24.62	12	24	
	24.62	24.62	24	24	12 (11.50)
	24.62	12.62	24	12	
	12.62	24.62	12	24	
Type 304 Stainless Steel <sup>B</sup>	24.62	24.62	24	24	6 (5.88)
	24.62	12.62	24	12	
	12.62	24.62	12	24	
	24.62	24.62	24	24	12 (11.50)
	24.62	12.62	24	12	
	12.62	24.62	12	24	
Mild Steel <sup>A</sup>	24.62	24.62	24	24	6 (5.88)
	24.62	12.62	24	12	
	12.62	24.62	12	24	
	24.62	24.62	24	24	12 (11.50)
	24.62	12.62	24	12	
	12.62	24.62	12	24	

DATA NOTES:

<sup>A</sup> Galvanized steel and mild steel kits use zinc electroplated steel hardware.

<sup>B</sup> 304 Stainless steel kits use 304 stainless steel hardware.

Refer to Camfil Farr drawings for arrangements of Magna-Frame I/II/III and Magna-Grid absolute prefilter options.

# ABSOLUTE PREFILTER KITS

## Prefilter kits applied to 'undersize absolute filters

Material	Actual Dimensions (inches)		Actual HEPA Filter Dimensions		Depth (inches)
	Height	Width	Height	Width	
Galvanized Steel <sup>A</sup>	24	24	23.38	23.38	6 (5.88)
	24	12	23.38	11.38	
	12	24	11.38	23.38	
	24	24	23.38	23.38	12 (11.50)
	24	12	23.38	11.38	
	12	24	11.38	23.38	
Type 304 Stainless Steel <sup>B</sup>	24	24	23.38	23.38	6 (5.88)
	24	12	23.38	11.38	
	12	24	11.38	23.38	
	24	24	23.38	23.38	12 (11.50)
	24	12	23.38	11.38	
	12	24	11.38	23.38	
Mild Steel <sup>A</sup>	24	24	23.38	23.38	6 (5.88)
	24	12	23.38	11.38	
	12	24	11.38	23.38	
	24	24	23.38	23.38	12 (11.50)
	24	12	23.38	11.38	
	12	24	11.38	23.38	

## SPECIFICATIONS

### 1.0 General

**1.1** - Absolute prefilter kit shall provide a single assembly of front service filtration including up to two stages of prefiltration, attaching to a single stage of final absolute filtration. All filters, fasteners, swing bolt assemblies and framing shall be of single manufacturer.

**1.2** - Sizes shall be as noted on drawings or other supporting materials.

### 2.0 - Construction

**2.1** - Absolute prefilter kit shall include universal holding frame constructed of 16-gauge galvanized steel (20-gauge 304 stainless steel). It shall be equipped with polyurethane foam gaskets and filter centering dimples. The four sealing flange comers shall be flush mitered in order to form a uniform sealing and gasketing surface. The frame in-line depth shall not be less than 2.69" in order to affect adequate bearing surface for built-up filter banks. The holding frame shall be designed to accommodate standard size filters with the application of the appropriate type fasteners.

**2.2** - The prefilter kit shall include the required number of 5/16" swing bolts. Bolts shall be of the same construction as the holding frame and shall be provided with equi-bearing clamps to secure absolute filter to absolute mounting assembly. ASHRAE filter support assemblies shall be provided to create a continuous filtration assembly of absolute, high efficiency ASHRAE filter and ASHRAE grade prefilter.

**2.3** - Filter fasteners shall be capable of being installed without the requirement of tools, nuts or bolts. An appropriate number of fasteners shall be included with each prefilter kit to match the filters on the enclosed drawings or specifications.

### 3.0 - Performance

**3.1** - Swing bolt assemblies shall be capable of sealing each absolute filter element with 30 inch/lb. of torque, providing for 50% gasket compression.

\* Items in parentheses ( ) denote optional construction selection.

*Camfil Farr has a policy of uninterrupted research, development and product improvement. We reserve the right to change designs and specifications without notice.*

### Camfil Farr, Inc.

United States Tel: (973) 616-7300 Fax: (973) 616-7771  
 Canada Tel: (450) 629-3030 Fax: (450) 662-6035  
 E-mail: camfilfarr@camfilfarr.com

© Camfil Farr

<http://www.camfilfarr.info>  
<http://www.camfilfarr.com>

